

# Solar Pod



The Solar Pod is exclusive to Blue Diamond in Australia.

It is designed to be easily installed with poly base that when in position can be filled with water or sand to hold it in position.

This unique system has been developed for Off Grid Power Systems where there is not a huge amount space free to include solar.

Even by adding 3 KW – 9KW of solar into a Hybrid Package, there will be significant increases in diesel savings compared to just diesel and battery.

Other uses can include stock watering, or any application where a small amount of power is required in an off grid application.



# Solar Pod

BALLAST SYSTEM SOLAR POD

TECHNICAL DOCUMENTATION



# Solar Pod

## 1. General description

Ballast tanks are plastic elements for mounting photovoltaic panels. The filling aperture is located in the rear wall. The ballast tank can be filled with antifreeze or loose material such as sand. Trapezoidal bridges for the installation of PV panels are installed on the upper surface of the tank. The surface on which the trapezoidal bridges are mounted is inclined to the base at an angle of  $21^\circ$ , this angle cannot be adjusted in the system. The tank has a holder at the bottom part, preventing the PV panel from sliding off. The tank has a handle for transporting the tanks. On the front and rear walls, there are additional fixing inserts for the possible joining of the tanks into groups or for fixing them to the ground.



Fig.1 Ballast tank Solar Pod

## 2. The required construction parameters

The weight of the filled tank allows the transfer of loads resulting from the wind determined for average conditions in Central Europe. In general, in terms of loads on the supporting structure, the proposed solution requires the use of supporting structures for the covering with parameters analogous to other solutions used so far.

In this respect, it is noteworthy that the tank can be additionally attached to the supporting structure for example, for greater roof pitch or other conditions. For this purpose, appropriate sockets for fastening elements have been prepared on the front and rear walls of the tank.

Important parameters:

- operating temperature from  $-25^\circ\text{C}$  to  $+70^\circ\text{C}$ ,
- mounting rails with a slot for the M8 screw,
- the tank has M8 threaded inserts for connecting the tanks into a ballast system.

# Solar Pod

## 3. Advantages of the system in terms of assembly and use

The distinguishing feature of the proposed solution is the ease of installation. It is possible to mount a wide range of photovoltaic panels available on the market. Due to the low weight of the tank (10 kg own weight with glycol concentrate), the ballast unfilled with water can be carried by one installer. The lack of sharp edges does not pose a risk of damaging the roof covering, and the tank is refilled with water only after it has been laid and stabilized on the roof.

## 4. Special conditions of use

Ballast tanks are filled with a slow-freezing fluid. Is a mixture of the water and the glycol concentrate in the tank. It is necessary to ensure that the tanks are constantly filled with a fluid of an appropriate concentration and parameters.

In accordance with the provisions of the law, roofs require periodic inspections, including before and after winter. In addition, the photovoltaic installation must be checked. At least during these checks, the condition of the ballast tanks and the filling solution should be checked.

## 5. Technical requirements

- It is recommended to use the ballast system in accordance with its application .
- The system can be used for typical flat roof coverings, in particular for roofs covered with plastic membranes, which are sensitive to mechanical damage from pressure and sharp edges.
- The system can also be installed on the ground after its prior reduction (levelling) and laying of a layer preventing the overgrowth of plants (e.g. geotextile or garden mats).
- In the case of installation on a flat roof with a slope angle of up to 10°, there must be a flat surface and the contact surface Surf between the ground and the tank bottom surface must not be less than  $\text{Surf} \geq 75\%$ .
- It is permissible to install on a flat roof with a slope angle of more than 10° provided that glue is used or the roof is fixed with mounting elements connected to the front or rear wall of the tank with M8 screws.
- The tightening torque of the fixing bolts on the faces must not exceed 8.5 Nm.
- When mounted on the roof or ground, sharp elements and edges which could damage the surface of the tank under pressure are not permitted.
- The ballast system is intended for installation only by qualified persons with appropriate knowledge and experience in the installation of photovoltaic installations.
- The surface on which the trapezoidal bridges are mounted is inclined to the base at an angle of 21 degrees; it is not possible to adjust this angle in the system and it is forbidden to use additional elements or change the construction under the risk of warranty loss.
- The tanks should be placed in such a way as not to impede the flow of rainwater and melting snow, i.e. with the longer side in the direction of the slope (installation on the

# Solar Pod

"shorter" side of the PV panel in accordance with the panel manufacturer's recommendations).

- Ballast tanks can be transported to the roof manually, using a skip, lift or crane.
- The tank has a handle at the bottom to prevent the panel from slipping off the ballast. The panel can be placed on the tanks before filling with water and tightening the fixing. More panels should not be stored on ballast tanks.
- The ballast system can be arranged in either S (south) or EW (east-west) orientation.



Fig. 2 S mounting method



Fig. 3 EW mounting method

- The presented ways of placing ballast tanks are only an example. The appropriate setting is individual for each installation and depends on the constructor involved in the design of the photovoltaic installation.
- The tank is supplied to the user together with the glycol concentrate and weighs 10kg, therefore to determine the recommended mass of 60kg, 50L of mains water must be added to the tank, which results in the recommended mass and concentration of the glycol solution of 10.7%.
- Add water with a garden hose using the water meter. After filling with water, the filling hole must be closed tightly with the attached plug.
- It is not permitted to fill the tank with other liquids and in an indicative manner.
- The electrical connections must be protected against flooding when refilling the tanks with water.
- When installing the panels, use clamps, screws and grooves suitable for trapezoidal bridges.
- Clamps, screws and grooves are not part of the ballast system; they must be selected individually and according to the type of PV panels to be installed.

# Solar Pod

- For the installation of PV panels, grouping of tanks, fixing of tanks to the roof or ground, the use of plastic screws and self-drilling screws is not allowed due to the risk of damaging the tank surface.
- Do not drill or penetrate the tank surface.

## 6. Technical description of possible solutions

Contrary to the previously known solutions, Solar Pod is characterized by a lower weight (max. 4 kg without fluid), which enables its easy transport, while maintaining durability, and mechanical strength and ensuring the stability of the structure, and the absence of sharp edges that could mechanically damage the surface of the roof. The features of the Solar Pod are its low weight, high load-bearing capacity, and stability as well as ergonomic shape without sharp edges. a plastic ballast tank for photovoltaic panels characterized in that it has the shape of a preferably truncated pyramid with a hollow chamber inside, the upper base of which is set

at an angle between 0 and 35° to the lower base of a square base, rectangular, trapezoid or quadrilateral in shape and has at least one filling aperture and at least one blind mounting opening on the upper base, and in the vertical cross-section it is approximately a triangle or a quadrilateral, preferably a trapezoid. Preferably, the pyramid has a vertical cross-sectional shape of a preferably right-angled triangle or a preferably right-angled quadrilateral. Preferably, it has at least one transport handle on the upper base preferably U-shaped or oblong, preferably of circular or quadrilateral cross-section. Preferably, in the upper base under the transport handle, there is an approximately U-shaped recess. Preferably, the filling aperture is located in the rear wall or the sidewall, or the upper base. Preferably, there are 1 to 5 filling apertures. Preferably, there are 1 to 20 mounting holes and preferably on the upper base. Preferably, the upper base has the shape in a cross-section of a straight broken line consisting of five sections, whose sections O1 and O3 are parallel to the lower base, and whose sections

O2 and O5 are included in a single straight line intersecting at an angle of 0 to 35° the line containing the longer side of the lower base. Preferably, the upper base has a shape in the cross-section of a straight broken line consisting of six sections, whose sections O1, O3, and O6 are parallel to the lower base, and whose sections O2 and O5 are included in a single straight line intersecting at an angle from 0 to 35° the line containing the longer side of the lower base.

Preferably, the filling aperture is on the rear wall, preferably at a height  $H_c$ , where the ratio of the height  $H_c$  from the lower base to the axis of symmetry on the upper plane of the hole to the length  $L$  of the lower base is  $0.4 \div 0.45$ . Preferably, the ratio of the width  $W$  of the lower base to the length  $L$  of the lower base is  $0.35-0.45$  preferably  $0.4$ . Preferably, the ratio of the height  $H_L$  from section O1 of the upper base to the length  $L$  of the lower base is  $0.14$  to  $0.16$  preferably  $0.15$ . Preferably, the ratio of the height  $H_M$  from section O3 of the upper base to the length  $L$  of the lower base is  $0.24$  to  $0.26$ , preferably  $0.25$ . Preferably, the ratio of the height  $H_H$  from section O6 of the upper base to the length  $L$  of the lower base is  $0.44$  to  $0.46$ . Preferably, the ratio of the inclination angle  $\alpha$  of the upper base to the lower base, excluding the sections parallel to the lower base, is  $A/L=0.015 \div 0.04$ , preferably  $21^\circ$ .

Preferably, it has vertical convex ribs on the sidewalls, preferably in a number from 1 to 14. Preferably, the ribs are along with the entire height of the sidewall, preferably arranged in a parallel way, preferably at equal distances. Preferably, it has 1 to 10 mounting holes on the

# Solar Pod

upper base, preferably four mounting holes. Preferably, the mounting holes are equally spaced from a straight line defined by the axis of symmetry of the upper base. Preferably, in the front wall, it has at least one blind front mounting hole, preferably four, most preferably symmetrically arranged with respect to the vertical axis of the front wall. Preferably, the rear wall has at least one rear blind mounting hole, preferably four, most preferably symmetrically arranged with respect to the vertical axis of the rear wall. Preferably, in the rear wall, it has at least one, preferably one to four horizontal convex ribs.

The ballast tank is used in particular as a structural mounting element primarily on flat roofs, especially for the installation of photovoltaic panels, but also on pitched roofs with a slope of up to  $10^\circ$ . The ballast tank is made of plastic with high mechanical strength, high melting point, a high barrier against gases, and high chemical resistance. The overall dimensions vary depending on the volume and the purpose of the tank, for the components to be installed. These dimensions change in proportion to the length of the tank L.

The ballast tank is disclosed in the drawings, in which figs. 1, 2, and 12 show the tank in a general isometric view, Fig.3 in a side view, Fig. 4 in a top view, and Figs. 5 and 6 arrangement of mounting holes, Figs. 7 and 8 the location of the filling aperture, Fig. 9 a "transport" handle, and Figs. 10 and 11 examples of the arrangement of the ribs on the bottom and sides of the tank.

## Example. I

The plastic ballast tank for photovoltaic panels has the shape of a truncated pyramid. It has an empty chamber inside. The chamber can be filled with water with glycol or bulk material.

The upper base 1 of the tank is set at an angle of  $21^\circ$  to the lower base 2 with a rectangular base and has one filling aperture 3 and four blind mounting holes 4 on the upper base 1. In the vertical cross-section, it is a rectangular trapezoid.

The tank has an elongated transport handle 5 with a circular cross-section. The transport handle 5 is on the upper base 1 and under the transport handle 5 there is an approximately U-shaped recess 13. The filling aperture 3 is located in the rear wall 6.

The upper base 1 has the shape in a cross-section of a straight broken line consisting of six sections, whose sections O1, O3, and O6 are parallel to the lower base, and whose sections O2 and O5 are included in a single straight line intersecting at an angle of  $21^\circ$  the straight line containing the longer side of the lower base 2. Section O4 constitutes a recess with a transport handle 5.

The filling aperture 3 is on the rear wall 6, at a height  $H_c$ , where the ratio of the height  $H_c$  from the lower base to the axis of symmetry on the upper plane of the hole to the length L of the lower base 2 is 0.4.

The ratio of the width W of the lower base 2 to the length L of the lower base 2 is 0.4.

The ratio of the height HL from the section O1 of the upper base 1 to the length L of the lower base 2 is 0.15.

The ratio of the height HM from section O3 of the upper base 1 to the length L of the bottom base 2 is 0.25.

The ratio of the height HH from section O6 of the upper base 1 to the length L of the lower base 2 is 0.45.

The ratio of the angle  $\alpha$  of the inclination of the upper base 1 to the lower base 2, excluding the sections parallel to the lower base 2, is  $21^\circ$ .

# Solar Pod

The tank on the side walls 7 has vertical convex ribs 8, seven in number. The ribs 8 are along with the entire height of the sidewall 7, arranged in parallel, at equal distances.

The mounting holes 4 are spaced at equal distances from a straight line defined by the axis of symmetry of the upper base 1.

In the front wall 9, there are four front mounting holes 10 arranged symmetrically with respect to the vertical axis of symmetry of the front wall 9.

In the rear wall 6, there are four blind rear mounting holes 11 arranged symmetrically with respect to the vertical axis of symmetry of the rear wall 6.

In the rear wall 6, there are two convex horizontal ribs 12, across the entire width of the rear wall 6, arranged in parallel, at equal distances.

## Example II.

A plastic ballast tank for photovoltaic panels has the shape of a pyramid with a hollow chamber inside, whose upper base 1 is set at an angle of  $12^\circ$  to the lower base 2 with a square base and has one filling aperture 3 on the rear wall 6 and four blind mounting holes 4 on the upper base 1 and is triangular in vertical cross-section.

## Example III.

A plastic ballast tank for photovoltaic panels has the shape of a truncated pyramid with a hollow chamber inside, whose upper base 1 is set at an angle of  $25^\circ$  to the lower base 2 with a rectangular base and has one filling aperture 3 on the rear wall and four blind mounting holes 4 on the upper base 1 and is trapezoidal in vertical cross-section.

## Example IV.

A plastic ballast tank for photovoltaic panels has the shape of a truncated pyramid with a hollow chamber inside, whose upper base 1 is set at an angle of  $25^\circ$  to the lower base 2 with a rectangular base and has one filling aperture 3 and four blind mounting holes 4 on the upper base 1 and is trapezoidal in vertical cross-section. The mounting holes 4 are arranged at equal distances from the straight line defined by the axis of symmetry of the upper base 1.

The tank has one elongated transport handle 5 on the upper base 1 with a circular cross-section.

In the upper base 1 under the transport handle 5, there is an approximately U-shaped recess 13. The filling aperture 3 is located in the rear wall 6.

The upper base 1 has the shape in a cross-section of a straight broken line consisting of five sections, whose sections O1 and O3 are parallel to the lower base 2, and whose sections O2 and O5 comprise a single straight line intersecting at an angle of  $21^\circ$  the straight line containing the longer side of the lower base 2. Section O4 constitutes a recess with a transport handle 5. The filling aperture 3 is on the rear wall 6, at a height  $H_c$ , where the ratio of the height  $H_c$  from the lower base 2 to the axis of symmetry on the upper plane of the filling aperture 3 to the length  $L$  of the lower base 2 is 0.45.

The ratio of the width  $W$  of the lower base 2 to the length  $L$  of the lower base 2 is 0.4.

The ratio of the height  $H_L$  from the section O1 of the upper base 1 to the length  $L$  of the lower base 2 is 0.15.

The ratio of the height  $H_M$  from section O3 of the upper base 1 to the length  $L$  of the lower base 2 is 0.25.

# Solar Pod

The ratio of the height HH from section O6 of the upper base 1 to the length L of the lower base 2 is 0.45.

The ratio of the angle  $\alpha$  of the inclination of the upper base 1 to the lower base 2, excluding the sections parallel to the lower base 2, is  $21^\circ$ .

On the side walls 7, the tank has vertical convex ribs 8, seven in number. The ribs 8 are along with the entire height of the sidewall 7, arranged in parallel, at equal distances.

The front wall 9 has four blind front mounting holes 10, symmetrically arranged with respect to the vertical axis of the front wall 9. The rear wall 6 has four blind rear mounting holes 11, symmetrically arranged with respect to the vertical axis of the rear wall 6. The rear wall 6 has two horizontal convex ribs 12.

## Example V.

Example V differs from the example I in that the rear wall 6 has a deflection 14 in the upper part, on which this deflection 14 the filling aperture 3 is seated. Preferably, the axis of the filling aperture 3 is inclined to the lower base 2 at an angle of  $30^\circ$ .

## Example VI.

Example VI differs from example IV in that the lower base 2 is trapezoidal and in vertical cross-section, the tank is trapezoidal in shape. The tank has blind mounting holes 4 in a number of six on the upper base 1. The mounting holes 4 are arranged at equal distances from the straight line defined by the axis of symmetry of the upper base 1.

The tank has a transport handle 5 on the upper base 1 in a U-shape.

The filling aperture 3 is located in the sidewall 7.

The tank has 20 mounting holes.

On the side walls 7, the tank has vertical convex ribs 8, four in number. The ribs 8 are not at the entire height of the sidewall 7 - they are at different heights, arranged in parallel, and at different distances.

The filling aperture 3 is on the back wall 6, at a height Hc, where the ratio of the height Hc from the lower base 2 to the axis of symmetry on the upper plane of the hole to the length L of the lower base 2 is 0.4.

The ratio of the width W of the lower base 2 to the length L of the lower base 2 is 0.35

The ratio of the height HL from section O1 of the upper base 1 to the length L of the lower base 2 is 0.16.

The ratio of the height HM from section O3 of the upper base 1 to the length L of the lower base 2 is 0.26.

The ratio of the height HH from section O6 of the upper base 1 to the length L of the lower base 2 is 0.46.

The ratio of the angle  $\alpha$  of the inclination of the upper base 1 to the lower base 2, excluding the sections parallel to the lower base 2, is  $32^\circ$ .

## Example VII

Example VI differs from example IV in that the filling aperture 3 is in the upper base 1.

The filling aperture 3 is on the rear wall 6, at a height Hc, where the ratio of the height Hc from the lower base 2 to the axis of symmetry on the upper plane of the opening to the length L of the lower base 2 is 0.45.

The ratio of the width W of the lower base 2 to the length L of the lower base 2 is 0.45.

# Solar Pod

The ratio of the height HL from section O1 of the upper base 1 to the length L of the lower base 2 is 0.14.

The ratio of the height HM from section O3 of the upper base 1 to the length L of the lower base 2 is 0.24.

The ratio of the height HH from section O6 of the upper base 1 to length L of the lower base 2 is 0.44.

The ratio of the angle  $\alpha$  of the inclination of the upper base 1 to the lower base 2, excluding the sections parallel to the lower base 2, is  $10^\circ$ .

## Example VIII

Example VIII differs from Example IV in that the tank has two filling apertures 3 - one in the rear wall 6 and the other in the sidewall 7.

## 7. Dismantling and recycling



A used product must not be treated as municipal waste. Disassembled product must be taken to a recycling centre for disposal. The proper disposal of the used product prevents potential negative environmental impacts that could occur in case of inappropriate waste management.

For more detailed information on recycling the product, please contact your local council or waste management service.

## 8. Nameplate

<b>Ballast tank Solar Pod</b>
Series nr/month/year Glycol concentrate vol. X Liter
<b>Series 001/01/2022</b> <b>Glycol concentrate vol. 5,5 L</b>

# Solar Pod

## 9. Figures

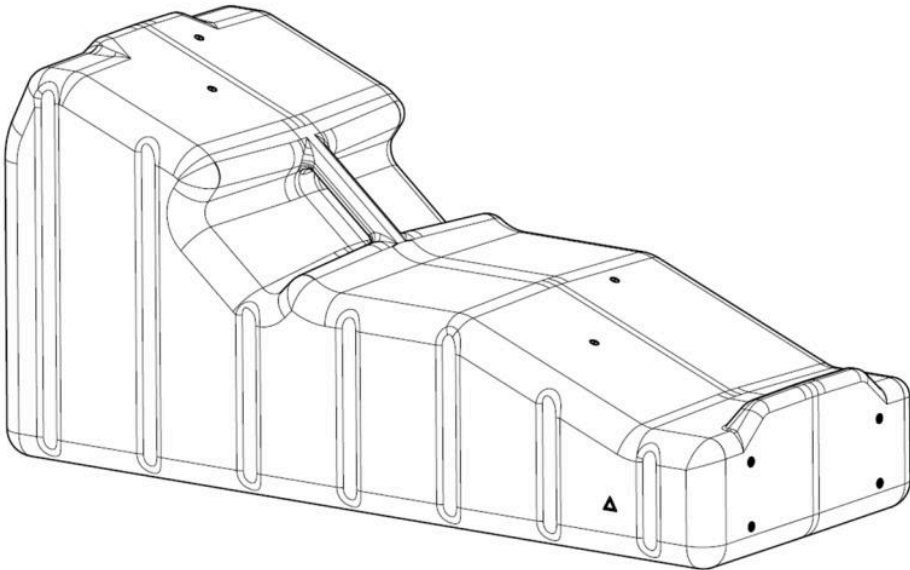

Fig. 1

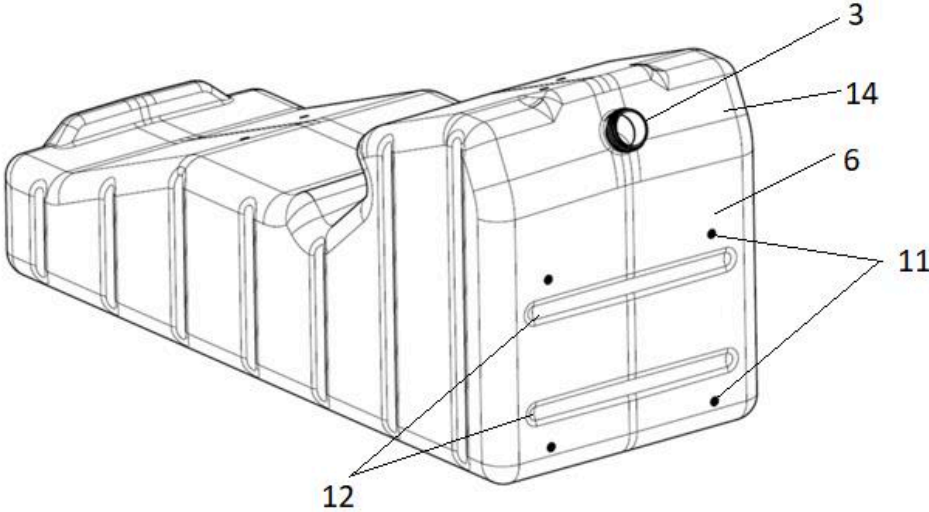

Fig. 2

# Solar Pod

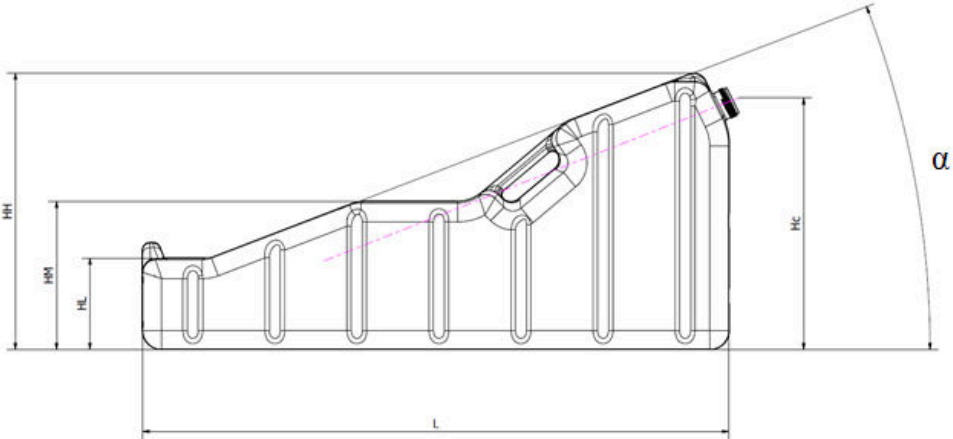

Fig. 3

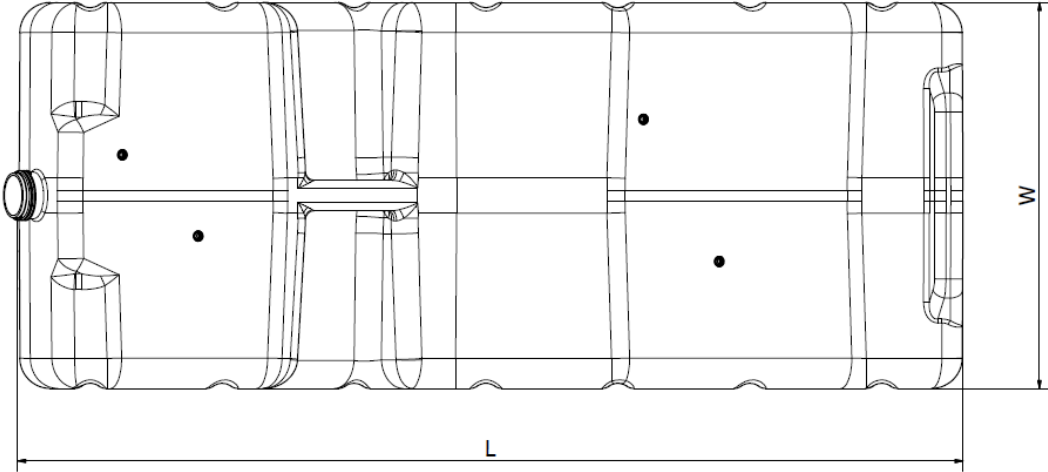

Fig. 4

# Solar Pod

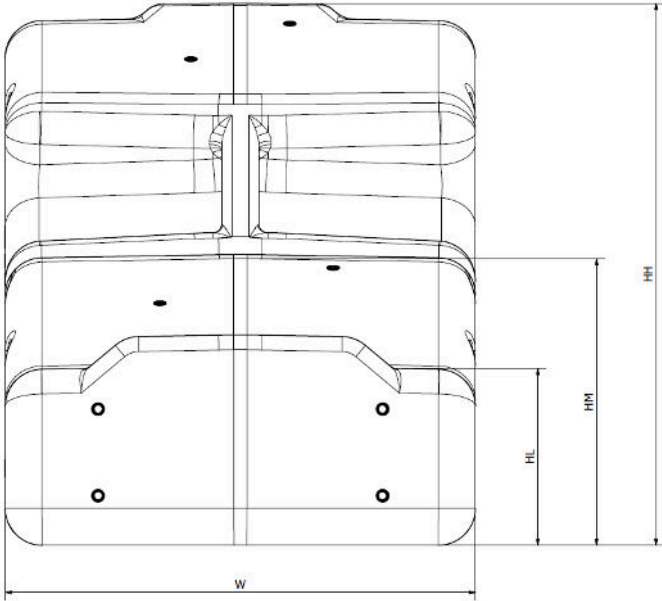
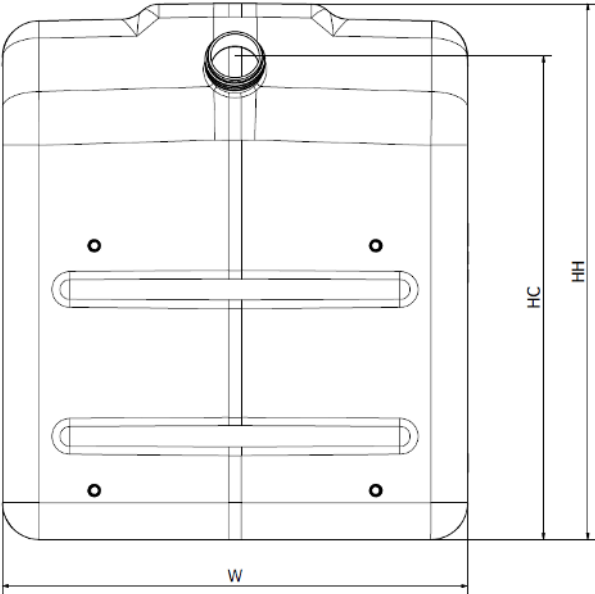

Fig. 5



# Solar Pod

Fig. 6

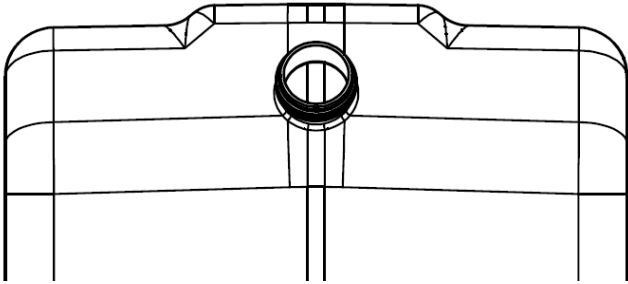

Fig. 7

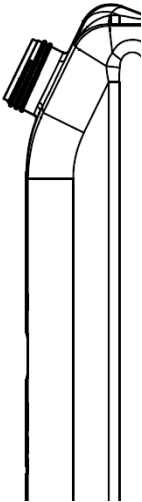

Fig. 8

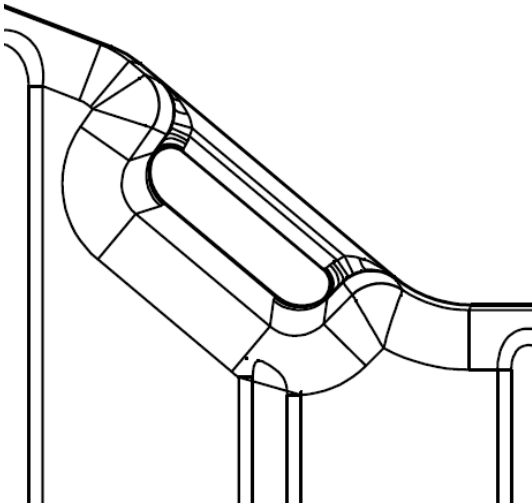

Fig. 9

# Solar Pod

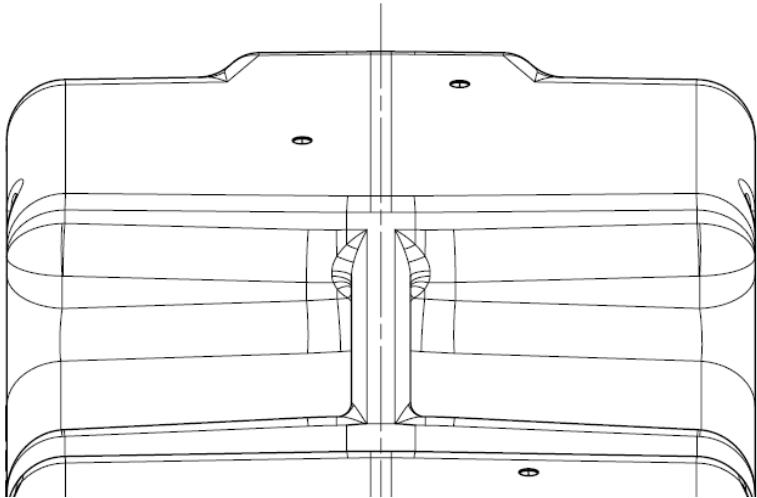
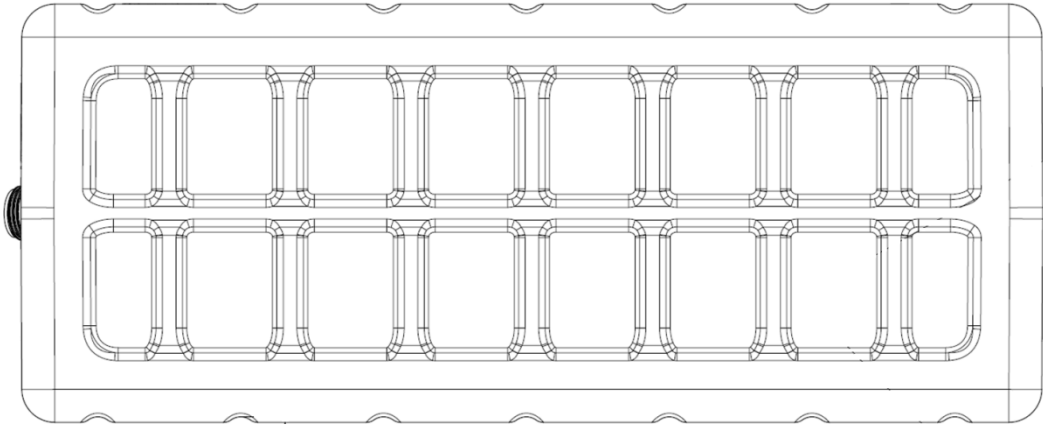

Fig. 10



# Solar Pod

Fig. 11

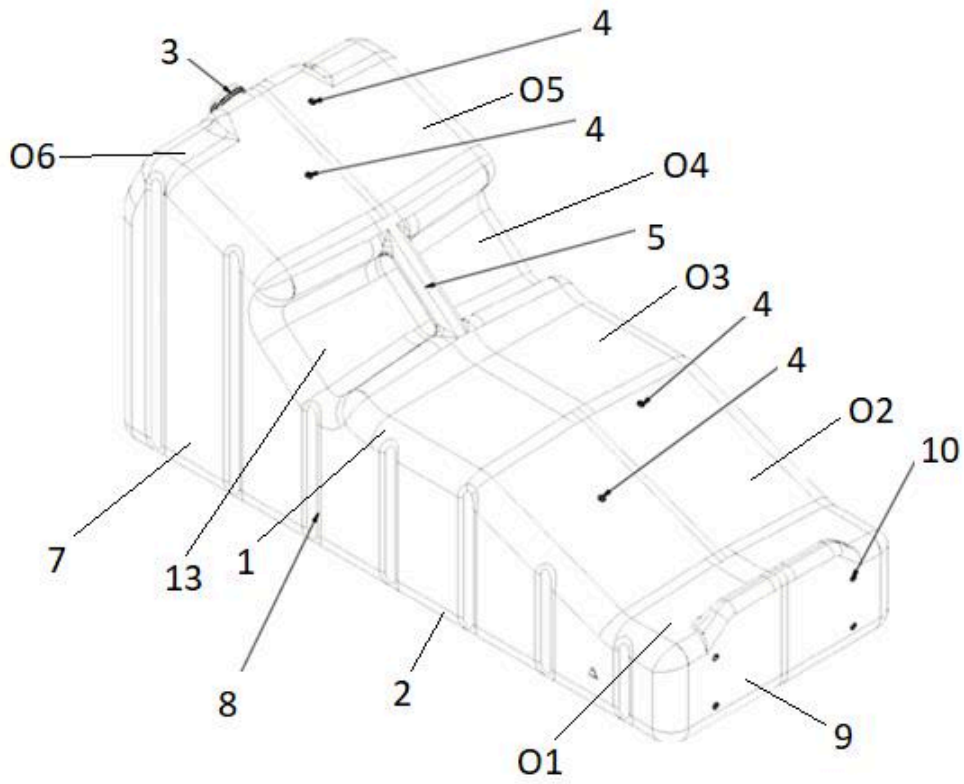
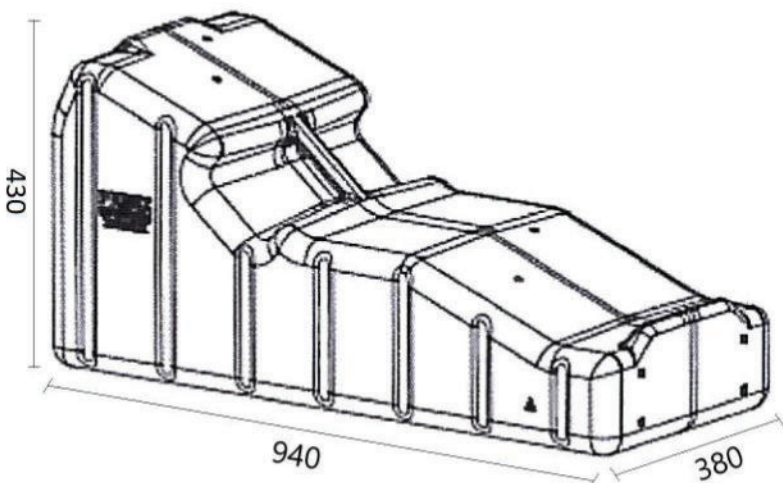

Fig. 12

# Solar Pod

## Solar Pod Ballast System

Dimensions:	94 cm x 38 cm x 43 cm
Material:	Polycarbonate (with aluminum mounting rails)
Roof Type:	Flat roof
Structure inclination angle:	23°
Panel layout:	Horizontal
Empty container weight:	4 kg
Weight of container filled with glycol concentrate:	10 kg
Weight of container filled with water:	60 kg
Guarantee:	25 years
Concrete exposure class:	XF4
Quantity on one pallet:	28 pcs
Temperature range:	Od -30°C do +70°C
Type of threaded inserts:	M8
Installation method:	South (S) or east-west (EW)
Minimum distance between rows:	1 m when mounted south (S)



### Contents of the Solar Pod:

- Liquid tank
- 2 aluminum rails
- 4 Allen screws
- 5,5L of glycol concentrate



South assembly

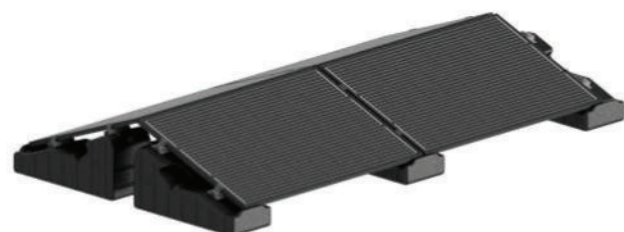

EW installation

# Solar Pod

## BALLAST SYSTEM SOLAR POD

### WARRANTY AND TERMS OF USE

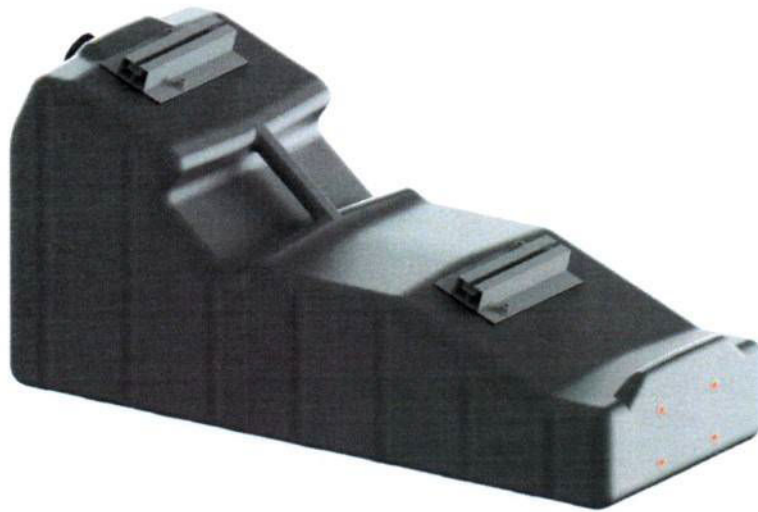

# Solar Pod

**Please read these instructions for use completely before using the ballast tank**

## **1. Technical parameters**

The weight of the filled tank allows the transfer of loads resulting from the wind determined for average conditions in Central Europe. In general, in terms of loads on the supporting structure, the proposed solution requires the use of supporting structures for the covering with parameters analogous to other solutions used so far.

In this respect, it is noteworthy that the tank can be additionally attached to the supporting structure for example, for greater roof pitch or other conditions. For this purpose, appropriate sockets for fastening elements have been prepared on the front and rear walls of the tank.

Important parameters:

- operating temperature from - 25°C to + 70°C,
- mounting rails with a slot for the M8 screw,
- the tank has M8 threaded inserts for connecting the tanks into a ballast system.

## **2. Advantages of the system in terms of assembly and use**

The distinguishing feature of the proposed solution is the ease of installation. It is possible to mount a wide range of photovoltaic panels available on the market. Due to the low weight of the tank (10 kg own weight with glycol concentrate), the ballast unfilled with water can be carried by one installer. The lack of sharp edges does not pose a risk of damaging the roof covering, and the tank is refilled with water only after it has been laid and stabilized on the roof.

## **3. Special terms of use**

Ballast tanks are filled with a slow-freezing fluid. Is a mixture of the water and the glycol concentrate in the tank. It is necessary to ensure that the tanks are constantly filled with a fluid of an appropriate concentration and parameters.

In accordance with the provisions of the law, roofs require periodic inspections, including before and after winter. In addition, the photovoltaic installation must be checked. At least during these checks, the condition of the ballast tanks and the filling solution should be checked.

## **4. Technical requirements**

- It is recommended to use the ballast system in accordance with its application .
- The system can be used for typical flat roof coverings, in particular for roofs covered with plastic membranes, which are sensitive to mechanical damage from pressure and sharp edges.

# Solar Pod

- The system can also be installed on the ground after its prior reduction (levelling) and laying of a layer preventing the overgrowth of plants (e.g. geotextile or garden mats).
- In the case of installation on a flat roof with a slope angle of up to 10°, there must be a flat surface and the contact surface Surf between the ground and the tank bottom surface must not be less than  $\text{Surf} \geq 75\%$ .
- It is permissible to install on a flat roof with a slope angle of more than 10° provided that glue is used or the roof is fixed with mounting elements connected to the front or rear wall of the tank with M8 screws.
- The tightening torque of the fixing bolts on the faces must not exceed 8.5 Nm.
- When mounted on the roof or ground, sharp elements and edges which could damage the surface of the tank under pressure are not permitted.
- The ballast system is intended for installation only by qualified persons with appropriate knowledge and experience in the installation of photovoltaic installations.
- The surface on which the trapezoidal bridges are mounted is inclined to the base at an angle of 21 degrees; it is not possible to adjust this angle in the system and it is forbidden to use additional elements or change the construction under the risk of warranty loss.
- The tanks should be placed in such a way as not to impede the flow of rainwater and melting snow, i.e. with the longer side in the direction of the slope (installation on the "shorter" side of the PV panel in accordance with the panel manufacturer's recommendations).
- Ballast tanks can be transported to the roof manually, using a skip, lift or crane.
- The tank has a handle at the bottom to prevent the panel from slipping off the ballast. The panel can be placed on the tanks before filling with water and tightening the fixing. More panels should not be stored on ballast tanks.
- The ballast system can be arranged in either S (south) or EW (east-west) orientation.



Fig. 2 S mounting method



Fig. 3 EW mounting method

# Solar Pod

- The presented ways of placing ballast tanks are only an example. The appropriate setting is individual for each installation and depends on the constructor involved in the design of the photovoltaic installation.
- The tank is supplied to the user together with the glycol concentrate and weighs 10kg, therefore to determine the recommended mass of 60kg, 50L of mains water must be added to the tank, which results in the recommended mass and concentration of the glycol solution of 10.7%.
- Add water with a garden hose using the water meter. After filling with water, the filling hole must be closed tightly with the attached plug.
- It is not permitted to fill the tank with other liquids and in an indicative manner.
- The electrical connections must be protected against flooding when refilling the tanks with water.
- When installing the panels, use clamps, screws and grooves suitable for trapezoidal bridges.
- Clamps, screws and grooves are not part of the ballast system; they must be selected individually and according to the type of PV panels to be installed.
- For the installation of PV panels, grouping of tanks, fixing of tanks to the roof or ground, the use of plastic screws and self-drilling screws is not allowed due to the risk of damaging the tank surface.
- Do not drill or penetrate the tank surface.

## 5. Terms of warranty

The basis of the warranty is the proof of purchase. The warranty starts on the date of invoice. The manufacturer give a 25-years warranty under the conditions set out in this instruction.

## 6. Ecology – environment protection and recycling

**Do not dispose into the domestic waste disposal!!!**



A used product must not be treated as municipal waste. Disassembled product must be taken to a recycling centre for disposal. The proper disposal of the used product prevents potential negative environmental impacts that could occur in case of inappropriate waste management.

For more detailed information on recycling the product, please contact your local council or waste management service.

**BLUE DIAMOND**  
MACHINERY

**NetZero**  
EQUIPMENT

[netzero.bluedm.com.au](http://netzero.bluedm.com.au)

**1300 998 647**